

**INSCAPE**

State of South Carolina

FREEFORM

US Price List

Contract #4400005978

August 2011



# FREEFORM® OFFICE SCREEN SYSTEM

---

Freeform® is a light screen-based office system that offers a distinctive alternative to traditional systems furniture. Freeform® may be used as an independent free-standing system or fully integrated with Platform's 3 ½" *Smart Spine* when there are technology requirements.

Freeform®'s lightweight screen construction and easy to install and reconfigure connections supports an ever changing office environment. Designed to accommodate individual or collaborative workspaces, Freeform creates an open office plan that suits a variety of needs in today's office.

With a wide range of fabric and hard surface screen core options, the 1 ½" thick screens adapt to any aesthetic demand. Freeform® screen cores are available in any of the standard Platform systems fabrics, approved COM (customer's own material) and fluted white or clear polycarbonate.

## **INSCAPE**

67 Toll Road, Holland Landing  
Ontario, Canada L9N 1H2  
Tel: 905 836 7676  
Fax: 1 800 563 7128 (North America)  
905 836 6001 (International)  
email: [custserv@inscapesolutions.com](mailto:custserv@inscapesolutions.com)

INSCAPE® is a wholly owned subsidiary of INSCAPE Corporation. Freeform® is a trademark of INSCAPE Corporation.



# FREEFORM

---

<b>Conditions of Sale</b>	<b>iv</b>	<b>Limited Lifetime Warranty</b>	<b>v</b>
Title and Freight	iv		
Shipping	iv		

---

<b>Screens</b>	<b>A</b>		
Statement of Line	A-1	Monolithic Screens - Resin & Polycarbonate	A-7
Overview	A-3	Monolithic Accessory Screens	A-8
General Information	A-3	Freestanding Screens	A-9
Segmented Screens	A-4	Table Mounted Screens	A-10
Glazed Segmented Screens	A-5	Open Screens (for use with Storwal)	A-11
Monolithic Screens - Fabric Covered	A-6		

---

<b>Connectors</b>	<b>B</b>		
Overview	B-1	Freeform to Platform Connectors	B-8
General Information	B-1	Platform to Freeform Connectors	B-9
Freeform to Freeform Connectors	B-7		

---

<b>Tables, Supports &amp; Electrical Accessories</b>	<b>C</b>		
Tables - Straight Edge	C-1	Supports	C-2
Tables - Tapered Edge	C-1	Electrical Accessories	C-3

---

<b>Surface Materials</b>	<b>D</b>		
--------------------------	----------	--	--

---

<b>Care and Maintenance</b>	<b>E</b>		
-----------------------------	----------	--	--

---

## Conditions of Sale

Reference to INSCAPE shall include INSCAPE Systems, except as specifically excepted and noted.

### Order Placement and Order Confirmation

All orders with INSCAPE must be placed in writing or electronically by the purchaser. Verbal orders are not accepted. All orders must be accepted and confirmed by INSCAPE in writing to be valid. INSCAPE manufactures, delivers and invoices based on the information in such written confirmation ("the Order Confirmation"). INSCAPE provides Order Confirmation by mail and/or facsimile. It is the purchaser's responsibility to advise INSCAPE of any information in the Order Confirmation that is incorrect within five (5) working days of receipt thereof, after which such Order Confirmation shall be deemed to be correct. The Order Confirmation, together with these Terms & Conditions, is intended and agreed by the purchaser to be the complete, exclusive and final statement of all terms and conditions of agreement between INSCAPE and the purchaser with respect to the purchase and sale of any INSCAPE product. No other terms and conditions shall apply to this agreement unless specifically agreed to in writing by an authorized officer of INSCAPE.

### Prices

All pricing (list, discounted, net, or otherwise) is for product only and is subject to change without notice. Without limiting the generality of the foregoing, prices do not include storage, insurance, taxes, local delivery or installation. Freight costs, except for freight charges, are included as set forth herein. Following freight surcharge applies to all orders.

\$ Net Order Value	USA East*	USA West*
<\$1,500	\$150	\$250
\$1,500 to \$5,000	3% of order value	5% of order value
>\$5,000	1% of order value	1% of order value

\* The USA West is defined as the States of Washington, Oregon, California, Montana, Idaho, Nevada and Arizona. The USA East is defined as all other contiguous US States.

### Minimum Order

All orders are subject to a minimum net charge of \$50.00.

### Title and Freight

All product shipped F.O.B. INSCAPE's factory in Holland Landing, Ontario or Falconer, New York depending on where the product is manufactured. Title to any product ordered and any risk of loss shall pass to the purchaser once delivered by INSCAPE to the carrier.

Subject to the various requirements and terms for shipping contained herein, freight costs, except freight surcharges, are prepaid and allowed to all points within the contiguous United States. In Canada, freight costs, except freight surcharges, are prepaid and allowed to Toronto, Montreal and Ottawa, only. Outside Canada and the

contiguous United States, freight is not included.

### Payment

INSCAPE invoices all orders in the currency indicated on the Order Confirmation. Payment must be made in this same currency and may be made by check or wire transfer.

Subject to credit approval, INSCAPE's standard payment terms are net 30 days from the invoice date. In cases where an order is placed with INSCAPE that puts an account over its assigned credit limit with INSCAPE, payment terms will be established at the time of order. Where credit terms have not been established, payment in full must be received at time of order placement. In all cases, the payment terms will be governed by the terms indicated on INSCAPE's Order Confirmation.

Delinquent accounts are subject to a 1 1/2% per month charge or the largest amount permitted by law, whichever is less. INSCAPE reserves the right to delay or cancel any shipment where an account is delinquent.

### Change and/or Cancellation of Order

As INSCAPE products are made to order the procurement and production processes begin well in advance of shipment. Therefore, requests for order changes or cancellations must be evaluated and approved by INSCAPE.

If a request is approved a cancellation change fee will apply and the delivery date may be adjusted. The fee will be determined by Customer Service and will be a percentage of the total order value. Please refer to the following chart as a guideline only:

Business Days before Acknowledged Ship Date	1-10	11-15	16-20	21 or greater
% of Total Order Value	100%	75%	50%	25%

Some order changes or cancellations may not get approved such as the following:

- Specials (not standard product).
- Special finishes including non standard paints.
- Long lead time finishes such as veneers.
- Orders requesting less than standard lead times.

When order changes or cancellations are not approved, 100% of the acknowledged order value will be charged.

All requests must be in writing by completing the Change Order Form, available on INSITE, and sent back to Customer Service. Inscap will review the request and if approved, will fax back the completed form, indicating applicable charges. The requestor is required to sign the form and return it to INSCAPE to acknowledge their acceptance.

Note that any change will be rescheduled and a new ship date will be determined.

# Conditions of Sale

---

## Specifications

All product specifications in INSCAPE's literature reflect product specifications in effect at the time the literature was published.

INSCAPE reserves the right to modify product and change product specifications at any time without notice.

## Orders Involving Customer's Own Material ("COM")

Use of any COM must be approved by INSCAPE by an Application Test prior to acceptance of order. INSCAPE requires sample fabric to assess whether the material is suitable for manufacturing on INSCAPE product. Panel fabrics that have stain retardant or do not meet UL requirements will not be approved nor accepted by INSCAPE and their adhesion will not be warranted. INSCAPE does not warranty any COM and assumes no responsibility for the appearance, durability, colorfastness or performance of any COM. Additional charges for certain COM materials may apply.

All COM supplied to INSCAPE must be and is assumed to be accurately manufactured, free of defects, production ready and identical to the sample fabric provided for the Application Test and does not warrant any fabric nor its adhesion if it is not. Color, style and quantity of COM supplied to INSCAPE are assumed to be correct. INSCAPE cannot be held responsible or liable for any inaccuracy or defect in the COM. Any delay in production due to an inaccuracy or defect and any additional costs which may result are the full responsibility of the customer.

All COM material must be shipped prepaid to INSCAPE with the following information clearly marked on the shipment:

- Name of the upholstery, design and color
- Total yardage provided for each material
- Customer's name
- Purchase order number
- COM approval number.

Orders, involving COM, will only be released and scheduled for production once all COM is on hand in sufficient quantity. INSCAPE is not liable for and will dispose of any excess COM yardage.

## Shipping

**Dates:** All Order Confirmations contain an estimated shipping date(s). This date(s) is approximate only and not guaranteed. INSCAPE shall in no way be liable to the purchaser or end user for any delays in meeting the estimated shipping date(s).

**Method and Carrier:** INSCAPE reserves the right to select the method of transportation and carrier of choice for any shipment.

**Deferral and Storage Terms:** The purchaser shall have 2 hours to off load a standard full load and 1 hour for an LTL. Waiting time charges shall apply afterwards. Where purchaser is unwilling or unable to accept delivery of any product that is permitted to be shipped by INSCAPE under the terms of this agreement, such product will be transferred into third party storage. Where the dealer or customer has not designated a storage site,

INSCAPE will transfer the goods to a location of its choice. Purchaser will be responsible and billed for any direct and related costs for such storage. INSCAPE shall not be liable for any damage or risk of loss incurred on product transferred into storage. Any product transferred into storage shall be deemed to constitute good delivery of such product by INSCAPE, whereupon INSCAPE shall have the right to invoice purchaser for such product as of the shipping date.

**Drop Shipments and Docking Requirements:** Except as provided in this paragraph, INSCAPE requires that all product be shipped only to the dealer's dock and that such docking facilities be equipped to handle a 53' tractor-trailer with appropriate personnel to offload the truck. Neither INSCAPE nor the carrier are responsible for offloading product from the truck.

In cases where INSCAPE determines that an order or portions thereof represent sufficient product to account for a complete trailer load, INSCAPE may agree, if requested by the purchaser, to ship directly to an end user, provided that the end user has the proper docking facilities and personnel to offload the truck as set forth above. Any portion of such order that is less than a trailer load quantity will be delivered to a dealer's warehouse, as stated above.

Product that cannot be delivered as a result of failure by the dealer or end user to meet the above requirements will be delivered to a warehouse, with redelivery at the purchaser's expense.

**Freight Damage Claims:** All INSCAPE products are carefully inspected prior to shipping and are packaged according to International Safe Transit Association (ISTA) standards. As such, purchaser is advised to examine the goods upon receipt as INSCAPE is not responsible for damage to goods that occur in transit or storage. In addition, Purchaser is advised that it must notify and file claims of any concealed damage to the product in accordance with the carrier's terms and conditions. In most cases, the carrier's requirements will include notification of any claims relating to concealed goods within 5 days of delivery and that a formal freight claim must be filed with the carrier within 60 days of delivery. In addition, most carriers require that all packaging be retained and available for inspection and the goods left at the original delivery point. Terms and conditions do vary from carrier to carrier and the purchaser is advised to consult with the carrier directly for details.

**Factory Claims:** Claims against INSCAPE, other than valid warranty claims, must be made in writing within 5 days after delivery, irrespective of whether product remains concealed at the delivery site. INSCAPE shall not be liable for any non-warranty claims, including but not limited to shortage claims, that are made after 5 days from the date of delivery.

**Requests for Special Shipping or Handling:** INSCAPE will make every effort to accommodate any special shipping or packaging requests, provided that INSCAPE reserves the right to charge purchaser with any direct or

## Conditions of Sale

---

indirect costs associated with meeting such requests if they go beyond INSCAPE's standard procedures.

**Shipping Weights and Cubic Dimensions:** All shipping weights and cubic dimensions, if provided by INSCAPE, are approximate.

### Limited Lifetime Warranty

In accordance with INSCAPE installation and application guidelines, INSCAPE provides a limited lifetime warranty to the original user on all INSCAPE products installed by an INSCAPE authorized installer.

The warranty extends to defects in material and workmanship in INSCAPE product. INSCAPE will repair, or at its option, provide comparable product, free of charge, products or parts proven to be defective within the warranty period. Provided that this warranty does not apply to:

Product that is damaged during shipment, installation or storage; Product that is damaged by the user as a result of accident, misuse, alteration, tampering, negligence, or abuse; Product that is not installed, used or maintained in accordance with INSCAPE's published guidelines; Products that have had safety devices, warnings or operating instructions on the product moved, removed or altered; Product that has in any way been altered, modified or substituted without INSCAPE's prior written consent and approval; Any material provided by the customer for the product (i.e. COM); Normal wear and tear; Claims and returns that are not made in accordance with INSCAPE claims and returns procedure outlined below; or parts or components not manufactured by INSCAPE, in which case the warranty is limited to the warranty that INSCAPE receives from the manufacturer of the defective part or component.

In addition, and without limiting the generality of the foregoing, INSCAPE's warranty is subject to the following specific limitations and exclusions: Fabrics and veneer components are warranted for a period of 5 years from the date of delivery; Non-standard products ("Specials") are warranted for a period of 1 year from date of delivery; Electrical components are limited to a warranty period of 10 years from date of delivery; Moving parts such as height-adjustable worksurface mechanisms and keyboard arms are warranted for a period of 5 years from date of delivery; Light bulbs, ballasts, fluorescent tubes and glass do not carry a warranty; The warranty does not cover variations in natural materials, color match, grain or texture beyond commercially acceptable standards; Incidental wear and tear to surface finishes including scratches and dents or fading of paint finishes and veneers; Any claims relating to defects in workmanship should be reported, in writing within 30 days of detection. The warranty does not apply to local code requirements other than UL, CSA and ANSI/BIFMA standards, which are the purchaser's and/or end user's responsibility to confirm; Claims for fabric defect must be made within 30 days of the date that the product is delivered.

### Claims and Returns Procedure

INSCAPE product may only be returned with INSCAPE's prior written authorization, whether or not such product is under warranty. All requests to return product must be made in writing to INSCAPE and include a description of the product, the reason for the return request, proof that the user is the original user, and evidence of the date that the product was originally delivered. No returned product will be accepted by INSCAPE without its prior written consent. Except in instances involving a valid warranty claim, returned product will be subject to shipping, handling, restocking and restoration charges.

### General Limitation on INSCAPE Liability

The warranty provisions contained herein represent the purchaser's and end user's sole remedy against INSCAPE for product defect. No other express or implied warranty is provided by INSCAPE. Without limiting the generality of the foregoing, INSCAPE makes no warranty as to fitness of purpose, use, or merchantability.

INSCAPE shall in no way and under no circumstances be liable for any incidental, economic, consequential, or exemplary damages.

### Governing Law

All orders and purchases of INSCAPE products shall be governed in all respects by the laws of the State of Delaware.

### INSCAPE Systems Office and Product Center:

67 Toll Road,  
Holland Landing, Ontario  
Canada L9N 1H2  
Telephone 905 836 7676  
Fax 800 563 7128 (North America)  
905 836 6001 (International)

email: [custserv@inscapesolutions.com](mailto:custserv@inscapesolutions.com)

web: [www.inscapesolutions.com](http://www.inscapesolutions.com)







# FREEFORM® STATEMENT OF LINE

## Screens

### 37" High Segmented Screen

Available Widths: 24", 30", 36", 42", 48", 54", 60"

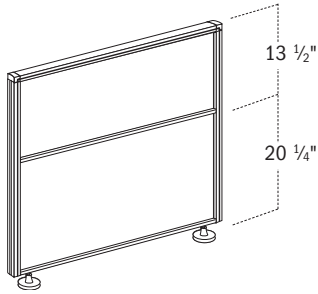

### 44" High Segmented Screen

Available Widths: 24", 30", 36", 42", 48", 54", 60"

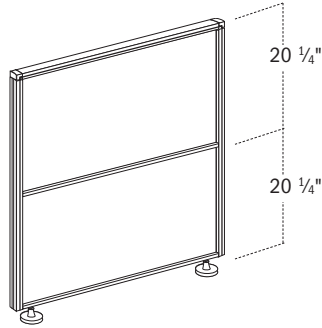

### 51" High Segmented Screen

Available Widths: 24", 30", 36", 42", 48", 54", 60"

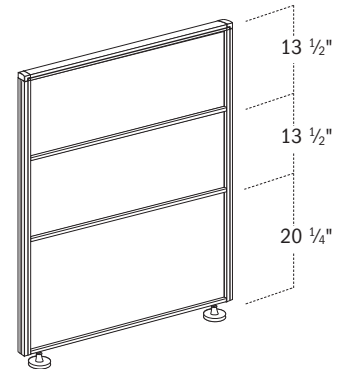

### 64" High Segmented Screen

Available Widths: 24", 30", 36", 42", 48", 54", 60"

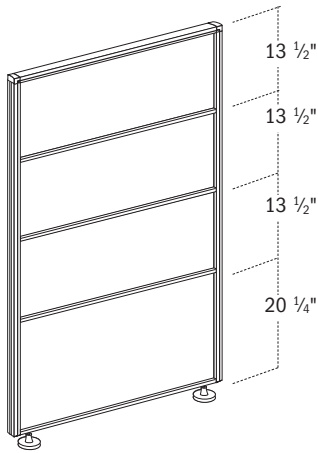

### 64" High Glazed Segmented Screen

Available Widths: 24", 30", 36", 42", 48", 54", 60"

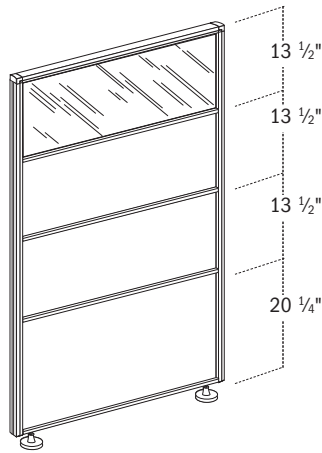

### Monolithic Screen

Available Heights: 37", 44", 51", 64"

Available Widths: 24", 30", 36", 42", 48", 54", 60"

**Note:** 64" Monolithic Screen available up to 48" wide

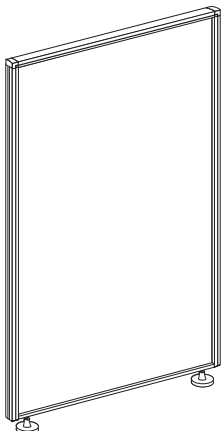

### Monolithic Accessory Screen

Available Heights: 51", 64"

Available Widths: 24", 30", 36", 42", 48", 54", 60"

**Note:** 64" Monolithic Accessory Screen available up to 48" wide

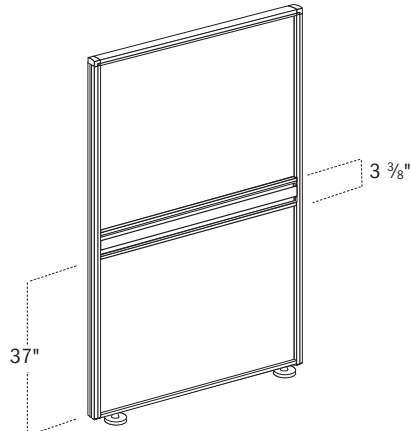

# FREEFORM® STATEMENT OF LINE

---

## Freestanding Screens

Freestanding Whiteboard Accessory Screen  
Available Heights: 51", 64"  
Available Widths: 36", 42", 48"

Freestanding Tackable Screen  
Available Heights: 51", 64"  
Available Widths: 36", 42", 48"

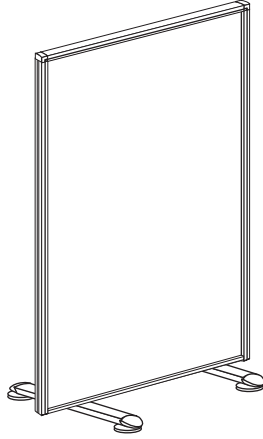
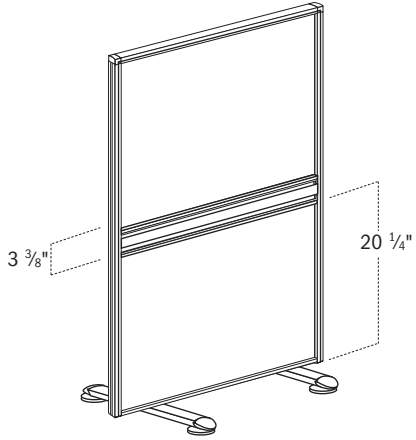

## Table Mounted Screens

Table Mounted Screen  
Available Heights: 37"  
Available Widths: 36", 42", 48", 54", 60"

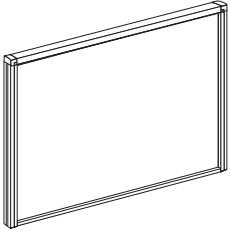

## Screens Overview

---

Freeform® consists of a variety of freestanding, table mounted and connectable screens that provide flexible and creative configuration options. Movable screens integrate with connectable screens and also have the ability to seamlessly integrate with Platform's 3 1/2" Smart Spine when there is a heavy demand for power and technology.

Freeform® Screen frames are 1 1/2" thick and are constructed of lightweight, extruded aluminum. Screens are available in five heights 37", 44", 51", 64" and 71", offered in a range of widths depending on screen height and configuration specifications. Screen frames are supported by two, 2" round glides that provide 1 1/2" height adjustability. Freestanding screen frames are supported by two molded aluminum feet with two dome shaped black nylon slide glides on each foot for easy maneuverability over carpeted areas. Freestanding screen frames are shipped requiring some assembly on site. Connectable screens are shipped fully assembled and ready for installation.

Freeform® screens are manufactured from a lightweight fabric covered core or a fluted polycarbonate.

**Segmented Screens** are divided by a horizontal 5/8" high crossbar with module lines that match Platform Systems creating seamless integration with both systems. Tackable 1/2" fabric wrapped core segments may be specified with any of the standard Platform Systems fabric.

**Monolithic Screens** have a solid tackable fabric wrapped 1/2" thick core which may be specified in any of the Platform Systems fabric.

**Monolithic Accessory Screens** provide paper management capabilities with the addition of a 3 3/8" high Freeform accessory rail installed 37" above the bottom of the frame. Accessory trays may be specified from the Platform Horizontal Load Bar program. The entire screen core is finished in a tackable fabric wrapped 1/2" thick core that may be specified in any of the standard Platform systems fabrics.

**Freestanding Whiteboard Accessory Screens** have two segments separated by the 3 3/8" high Freeform accessory rail. Accessory trays may be specified from the Platform Horizontal Load Bar program. The top segment is a whiteboard surface while the bottom is finished in a tackable surface. All Whiteboard Accessory Screens include one marker tray which mounts on the accessory rail.

**Note:** Freeform® Accessory Rail accepts all Platform Horizontal Load Bar Trays. Please refer to Accessories section in the Platform Price List for pricing and product specifications. Freeform® and Platform accessory rails are not interchangeable, only accessories.

**Freeform-Storwal Open Screens** are to be specified between two Storwal cases.

**Table Mounted Screens** have the same 1 1/2" thick extruded aluminum frame, however, are designed to mount to the back of any Platform freestanding table of the same width. The tackable 1/2" thick fabric core may be specified in any of the standard Platform system fabrics. Screens are shipped with all required mounting hardware. **Specification Note:** Height adjustable brackets allow for various screen height positions. It is recommended that the table mounted screen be installed 20" above the surface with 16" below.

### Finishes

Screen frames are available in any of the colors shown in our Color Guide. Horizontal crossbars will be painted as per the frame finish specification. Tackable fabric wrapped core may be specified in COM fabrics or in the standard fabrics shown in the Platform Panel Fabric cards. COM fabrics are subject to approval.



Glazed segmented screens provide a glazed segment using 6mm Clear Acrylic or Resin. See Finish section for Resin finishes.

**Note:** Screen fabric finish specified will be applied to both sides and all segments of the screen.

Marker trays are finished to match the screen frame and accessory rail.

**INSCAPE whiteboards are specifically designed for use with DRY-ERASE markers only. WHITEBOARDS ARE NOT INTENDED FOR USE WITH PERMANENT MARKERS. INSCAPE advises the use of Sanford Expo Dry Erase markers with our whiteboards, for a thorough cleaning, use Sanford Expo Spray Cleaner.**

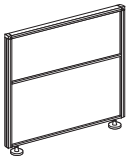
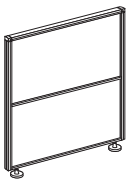
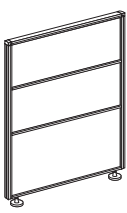
# Segmented Screens

Description	Product No.	H"	W"	Weight lbs.	Grade 1 / COM	Grade 2	Grade 3	Grade 5	Grade 7
<b>37" High</b>									
	SS3718	37	18	9	\$ 394	\$ 416	\$ 426	\$ 463	\$ 625
	SS3724	37	24	10	\$ 413	\$ 436	\$ 450	\$ 487	\$ 657
	SS3730	37	30	12	\$ 448	\$ 477	\$ 494	\$ 538	\$ 727
	SS3736	37	36	14	\$ 484	\$ 521	\$ 543	\$ 592	\$ 799
	SS3742	37	42	15	\$ 519	\$ 564	\$ 589	\$ 644	\$ 870
	SS3748	37	48	17	\$ 539	\$ 584	\$ 609	\$ 665	\$ 898
	SS3754	37	54	19	\$ 560	\$ 605	\$ 630	\$ 686	\$ 919
	SS3760	37	60	21	\$ 581	\$ 626	\$ 650	\$ 710	\$ 959
<b>44" High</b>									
	SS4418	44	18	11	\$ 415	\$ 440	\$ 453	\$ 494	\$ 667
	SS4424	44	24	12	\$ 438	\$ 465	\$ 481	\$ 521	\$ 704
	SS4430	44	30	14	\$ 478	\$ 515	\$ 535	\$ 582	\$ 786
	SS4436	44	36	15	\$ 516	\$ 562	\$ 586	\$ 642	\$ 867
	SS4442	44	42	17	\$ 557	\$ 612	\$ 641	\$ 702	\$ 948
	SS4448	44	48	19	\$ 580	\$ 634	\$ 664	\$ 726	\$ 980
	SS4454	44	54	21	\$ 601	\$ 656	\$ 687	\$ 751	\$ 1014
	SS4460	44	60	23	\$ 624	\$ 679	\$ 709	\$ 773	\$ 1044
<b>51" High</b>									
	SS5118	51	18	12	\$ 462	\$ 488	\$ 508	\$ 556	\$ 752
	SS5124	51	24	13	\$ 482	\$ 516	\$ 530	\$ 579	\$ 781
	SS5130	51	30	15	\$ 529	\$ 572	\$ 594	\$ 651	\$ 879
	SS5136	51	36	18	\$ 576	\$ 630	\$ 659	\$ 720	\$ 972
	SS5142	51	42	20	\$ 623	\$ 688	\$ 722	\$ 792	\$ 1069
	SS5148	51	48	22	\$ 649	\$ 714	\$ 748	\$ 818	\$ 1095
	SS5154	51	54	24	\$ 676	\$ 741	\$ 775	\$ 845	\$ 1122
	SS5160	51	60	26	\$ 702	\$ 768	\$ 803	\$ 877	\$ 1185
<b>64" High</b>									
	SS6418	64	18	12	\$ 544	\$ 585	\$ 604	\$ 660	\$ 890
	SS6424	64	24	16	\$ 551	\$ 593	\$ 616	\$ 673	\$ 908
	SS6430	64	30	19	\$ 610	\$ 668	\$ 697	\$ 763	\$ 1030
	SS6436	64	36	21	\$ 668	\$ 740	\$ 777	\$ 852	\$ 1150
	SS6442	64	42	23	\$ 728	\$ 814	\$ 857	\$ 943	\$ 1273
	SS6448	64	48	26	\$ 761	\$ 846	\$ 891	\$ 978	\$ 1321
	SS6454	64	54	29	\$ 793	\$ 878	\$ 924	\$ 1012	\$ 1366
	SS6460	64	60	32	\$ 825	\$ 911	\$ 955	\$ 1047	\$ 1413

# Glazed Segmented Screens

Description	Product No.	H"	W"	Grade 1 / COM	Grade 2	Grade 3	Grade 5	Grade 7
-------------	-------------	----	----	---------------	---------	---------	---------	---------

## 64" High with Clear Acrylic

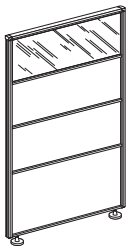

SSG6424	64	24	\$ 615	\$ 647	\$ 664	\$ 721	\$ 973
SSG6430	64	30	\$ 683	\$ 726	\$ 749	\$ 815	\$ 1101
SSG6436	64	36	\$ 749	\$ 804	\$ 834	\$ 905	\$ 1223
SSG6442	64	42	\$ 816	\$ 881	\$ 917	\$ 999	\$ 1348
SSG6448	64	48	\$ 895	\$ 960	\$ 996	\$ 1085	\$ 1465
SSG6454	64	54	\$ 972	\$ 1038	\$ 1073	\$ 1167	\$ 1576
SSG6460	64	60	\$ 1051	\$ 1117	\$ 1152	\$ 1246	\$ 1655

## 64" High with Grade 1 Resin



SSG6424	64	24	\$ 721	\$ 753	\$ 770	\$ 827	\$ 1079
SSG6430	64	30	\$ 826	\$ 869	\$ 892	\$ 958	\$ 1244
SSG6436	64	36	\$ 933	\$ 988	\$ 1018	\$ 1089	\$ 1407
SSG6442	64	42	\$ 1038	\$ 1103	\$ 1139	\$ 1221	\$ 1570
SSG6448	64	48	\$ 1211	\$ 1276	\$ 1312	\$ 1401	\$ 1781
SSG6454	64	54	\$ 1384	\$ 1450	\$ 1485	\$ 1579	\$ 1988
SSG6460	64	60	\$ 1557	\$ 1623	\$ 1658	\$ 1752	\$ 2161

## 64" High with Grade 2 Resin

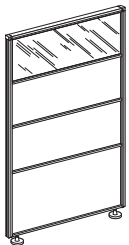





SSG6424	64	24	\$ 747	\$ 779	\$ 796	\$ 853	\$ 1105
SSG6430	64	30	\$ 863	\$ 906	\$ 929	\$ 995	\$ 1281
SSG6436	64	36	\$ 977	\$ 1032	\$ 1062	\$ 1133	\$ 1451
SSG6442	64	42	\$ 1091	\$ 1156	\$ 1192	\$ 1274	\$ 1623
SSG6448	64	48	\$ 1290	\$ 1355	\$ 1391	\$ 1480	\$ 1860
SSG6454	64	54	\$ 1484	\$ 1550	\$ 1585	\$ 1679	\$ 2088
SSG6460	64	60	\$ 1685	\$ 1751	\$ 1786	\$ 1880	\$ 2289

## 64" High with Grade 3 Resin







SSG6424	64	24	\$ 774	\$ 806	\$ 823	\$ 880	\$ 1132
SSG6430	64	30	\$ 898	\$ 941	\$ 964	\$ 1030	\$ 1316
SSG6436	64	36	\$ 1021	\$ 1076	\$ 1106	\$ 1177	\$ 1495
SSG6442	64	42	\$ 1145	\$ 1210	\$ 1246	\$ 1328	\$ 1677
SSG6448	64	48	\$ 1364	\$ 1429	\$ 1465	\$ 1554	\$ 1934
SSG6454	64	54	\$ 1583	\$ 1649	\$ 1684	\$ 1778	\$ 2187
SSG6460	64	60	\$ 1803	\$ 1869	\$ 1904	\$ 1998	\$ 2407

# Monolithic Screens - Fabric Covered

Description	Product No.	H"	W"	Weight lbs.	Grade 1 / COM	Grade 2	Grade 3	Grade 5	Grade 7
<b>37" High</b>									
	MS3718	37	18	9	\$ 328	\$ 350	\$ 362	\$ 394	\$ 532
	MS3724	37	24	10	\$ 354	\$ 376	\$ 388	\$ 420	\$ 567
	MS3730	37	30	11	\$ 386	\$ 414	\$ 431	\$ 468	\$ 632
	MS3736	37	36	13	\$ 418	\$ 455	\$ 476	\$ 517	\$ 697
	MS3742	37	42	15	\$ 449	\$ 492	\$ 516	\$ 566	\$ 764
	MS3748	37	48	16	\$ 467	\$ 511	\$ 535	\$ 585	\$ 789
	MS3754	37	54	18	\$ 486	\$ 530	\$ 554	\$ 606	\$ 818
	MS3760	37	60	19	\$ 505	\$ 548	\$ 572	\$ 626	\$ 845
<b>44" High</b>									
	MS4418	44	18	10	\$ 352	\$ 379	\$ 392	\$ 429	\$ 579
	MS4424	44	24	11	\$ 379	\$ 405	\$ 419	\$ 456	\$ 615
	MS4430	44	30	13	\$ 416	\$ 452	\$ 468	\$ 513	\$ 692
	MS4436	44	36	15	\$ 454	\$ 496	\$ 519	\$ 568	\$ 767
	MS4442	44	42	16	\$ 488	\$ 540	\$ 569	\$ 623	\$ 842
	MS4448	44	48	18	\$ 509	\$ 561	\$ 589	\$ 645	\$ 871
	MS4454	44	54	20	\$ 530	\$ 582	\$ 609	\$ 668	\$ 902
	MS4460	44	60	22	\$ 549	\$ 603	\$ 630	\$ 689	\$ 930
<b>51" High</b>									
	MS5118	51	18	11	\$ 374	\$ 404	\$ 419	\$ 459	\$ 620
	MS5124	51	24	13	\$ 404	\$ 434	\$ 451	\$ 491	\$ 663
	MS5130	51	30	15	\$ 445	\$ 486	\$ 508	\$ 555	\$ 749
	MS5136	51	36	17	\$ 487	\$ 536	\$ 565	\$ 620	\$ 838
	MS5142	51	42	19	\$ 528	\$ 589	\$ 620	\$ 683	\$ 923
	MS5148	51	48	21	\$ 549	\$ 611	\$ 642	\$ 707	\$ 954
	MS5154	51	54	23	\$ 571	\$ 633	\$ 664	\$ 731	\$ 987
	MS5160	51	60	25	\$ 593	\$ 655	\$ 686	\$ 753	\$ 1016
<b>64" High</b>									
	MS6418	64	18	12	\$ 396	\$ 434	\$ 450	\$ 495	\$ 668
	MS6424	64	24	16	\$ 432	\$ 478	\$ 495	\$ 548	\$ 739
	MS6430	64	30	18	\$ 481	\$ 520	\$ 541	\$ 591	\$ 798
	MS6436	64	36	21	\$ 580	\$ 605	\$ 699	\$ 771	\$ 1041
	MS6442	64	42	23	\$ 605	\$ 656	\$ 724	\$ 798	\$ 1077
	MS6448	64	48	25	\$ 632	\$ 711	\$ 751	\$ 825	\$ 1114
<b>71" High</b>									
	MS7118	71	18	14	\$ 466	\$ 508	\$ 526	\$ 576	\$ 778





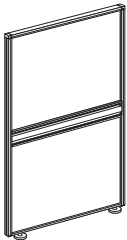
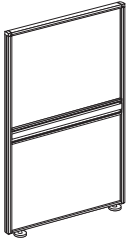

# Monolithic Screens - Resin & Polycarbonate

Description	Product No.	H"	W"	Weight lbs.	Grade 1 Resin	Grade 2 Resin	Grade 3 Resin	Clear Fluted	White Fluted
<b>37" High</b>									
	MS3724	37	24	10	\$ 656	\$ 726	\$ 790	\$ 418	\$ 418
	MS3730	37	30	11	\$ 814	\$ 911	\$ 999	\$ 431	\$ 431
	MS3736	37	36	13	\$ 973	\$ 1096	\$ 1209	\$ 443	\$ 443
	MS3742	37	42	15	\$ 1131	\$ 1281	\$ 1417	\$ 469	\$ 469
	MS3748	37	48	16	\$ 1291	\$ 1467	\$ 1626	\$ 503	\$ 503
<b>44" High</b>									
	MS4424	44	24	11	\$ 760	\$ 847	\$ 927	\$ 433	\$ 433
	MS4430	44	30	13	\$ 897	\$ 1006	\$ 1105	\$ 462	\$ 462
	MS4436	44	36	15	\$ 1033	\$ 1164	\$ 1284	\$ 492	\$ 492
	MS4442	44	42	16	\$ 1167	\$ 1321	\$ 1459	\$ 526	\$ 526
	MS4448	44	48	18	\$ 1301	\$ 1477	\$ 1635	\$ 560	\$ 560
<b>51" High</b>									
	MS5124	51	24	13	\$ 766	\$ 854	\$ 934	\$ 480	\$ 480
	MS5130	51	30	15	\$ 903	\$ 1013	\$ 1112	\$ 514	\$ 514
	MS5136	51	36	17	\$ 1038	\$ 1171	\$ 1289	\$ 551	\$ 551
	MS5142	51	42	19	\$ 1174	\$ 1328	\$ 1468	\$ 564	\$ 564
	MS5148	51	48	21	\$ 1308	\$ 1483	\$ 1643	\$ 576	\$ 576
<b>64" High</b>									
	MS6424	64	24	16	\$ 1337	\$ 1516	\$ 1674		
	MS6430	64	30	18	\$ 1564	\$ 1785	\$ 1985		
	MS6436	64	36	21	\$ 1791	\$ 2055	\$ 2296		
	MS6442	64	42	23	\$ 2017	\$ 2325	\$ 2606		
	MS6448	64	48	25	\$ 2244	\$ 2597	\$ 2917		

# Monolithic Accessory Screens

Description	Product No.	H"	W"	Weight lbs.	Grade 1 / COM	Grade 2	Grade 3	Grade 5	Grade 7
<b>51" High</b>									
	MAS5124	51	24	13	\$ 488	\$ 516	\$ 533	\$ 578	\$ 781
	MAS5130	51	30	14	\$ 537	\$ 575	\$ 597	\$ 649	\$ 876
	MAS5136	51	36	15	\$ 586	\$ 633	\$ 661	\$ 720	\$ 972
	MAS5142	51	42	15	\$ 633	\$ 692	\$ 722	\$ 792	\$ 1069
	MAS5148	51	48	16	\$ 663	\$ 722	\$ 752	\$ 822	\$ 1099
	MAS5154	51	54	17	\$ 692	\$ 751	\$ 782	\$ 855	\$ 1154
	MAS5160	51	60	18	\$ 721	\$ 782	\$ 812	\$ 886	\$ 1196
<b>64" High</b>									
	MAS6424	64	24	16	\$ 572	\$ 611	\$ 631	\$ 685	\$ 926
	MAS6430	64	30	17	\$ 618	\$ 668	\$ 696	\$ 759	\$ 1024
	MAS6436	64	36	18	\$ 665	\$ 728	\$ 762	\$ 833	\$ 1125
	MAS6442	64	42	18	\$ 711	\$ 787	\$ 827	\$ 906	\$ 1223
	MAS6448	64	48	19	\$ 743	\$ 819	\$ 860	\$ 943	\$ 1272

# Freestanding Screens

Description	Product No.	H"	W"	Weight lbs.	Grade 1 / COM	Grade 2	Grade 3	Grade 5	Grade 7
<b>51" High Whiteboard Accessory</b>									
	SASF5136	51	36	15	\$ 899	\$ 925	\$ 940	\$ 1013	\$ 1368
	SASF5142	51	42	15	\$ 936	\$ 962	\$ 976	\$ 1053	\$ 1421
	SASF5148	51	48	16	\$ 972	\$ 998	\$ 1013	\$ 1086	\$ 1441
<b>64" High Whiteboard Accessory</b>									
	SASF6436	64	36	18	\$ 964	\$ 990	\$ 1004	\$ 1089	\$ 1470
	SASF6442	64	42	18	\$ 1007	\$ 1033	\$ 1048	\$ 1128	\$ 1523
	SASF6448	64	48	19	\$ 1052	\$ 1078	\$ 1093	\$ 1173	\$ 1568
<b>51" High Tackable</b>									
	MSF5136	51	36	23	\$ 807	\$ 868	\$ 899	\$ 980	\$ 1324
	MSF5142	51	42	25	\$ 828	\$ 890	\$ 921	\$ 1004	\$ 1356
	MSF5148	51	48	27	\$ 851	\$ 913	\$ 944	\$ 1029	\$ 1390
<b>64" High Tackable</b>									
	MSF6436	64	36	28	\$ 880	\$ 959	\$ 1000	\$ 1093	\$ 1475
	MSF6442	64	42	31	\$ 905	\$ 984	\$ 1025	\$ 1118	\$ 1500
	MSF6448	64	48	33	\$ 931	\$ 1010	\$ 1051	\$ 1144	\$ 1526

# Table-Mounted Screens

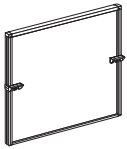
Description	Product No.	H"	W"	Weight lbs.	Grade 1 / COM	Grade 2	Grade 3	Grade 5	Grade 7
<b>37" High Table Mounted</b>									
	MST3736	37	36	13	\$ 467	\$ 511	\$ 535	\$ 587	\$ 799
	MST3742	37	42	15	\$ 486	\$ 529	\$ 554	\$ 606	\$ 818
	MST3748	37	48	16	\$ 505	\$ 547	\$ 572	\$ 626	\$ 845
	MST3754	37	54	18	\$ 523	\$ 567	\$ 591	\$ 646	\$ 872
	MST3760	37	60	19	\$ 542	\$ 587	\$ 610	\$ 665	\$ 898

# Storwal Compliments - Open Frames

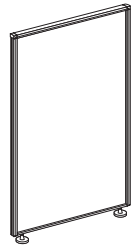
Description	Product No.	H"	W"	Weight lbs.	List Price
<b>Freeform-Storwal Frames</b>					
	<b>SWMS5118</b>	51	18	8	<b>\$287</b>
	<b>SWMS6418</b>	64	18	10	<b>\$314</b>
	<b>SWMS7118</b>	71	18	12	<b>\$387</b>



## **B Connectors**





## Connector Kit Overview

---

Freeform® Screens may be connected to Integrate with additional Freeform® Screens as well as Platform Frames.

**Freeform® to Platform connector kits** allow for a variety of connection options including off-module, back-to-back off-module, two way (L) and three way (T) conditions.

**Platform to Freeform® connector kits** allow for three-way (T) and four-way (X) conditions, including multi-height applications.

Vertical trim pieces, connector brackets and clips must be specified separately. To facilitate specification, all connection hardware and trim required to complete Freeform® to Platform or Platform to Freeform® configurations are available in kits.

Metal connector brackets create all conditions. A 3/16" and a 1/8" Allen key are all that is required to fasten to connector bolts for each condition providing easy installation and reconfigurations.

Clips within the two-way (L) and three-way (T) connector kits support the vertical trim. These clips are made of a resin called Delrin which is similar to nylon in strength with superior memory. These clips secure the painted 3.5" wide extruded aluminum trim to finish the condition.

### Product Code Key Example for Freeform® to Platform FSPTC37

**F** - Freeform  
**SP** - Screen to Platform  
**T** - 'T' Connection  
**C** - Connector Kit  
**37** - 37" High

**L' connectors** connect one Freeform® screen to a Platform frame at a 90° corner angle.

**T' connectors** connect two Freeform® screens to a Platform frame at two 90° angles.

**Specify with Tapered Vertical Trim only.**

### Product Code Key Example for Platform to Freeform® FPSTC37

**F** - Freeform  
**PS** - Platform to Screen  
**T** - 'T' Connection  
**C** - Connector Kit  
**37** - 37" High

**T' connectors** connect two Platform panels to one Freeform® screen at a 3-way 90° connection.

**X' connectors** connect two Platform panels to two Freeform® screens at a 4-way 90° connection.

**Specify with Tapered Vertical Trim only.**

### Ordering Information

In multi-height conditions, Platform panel heights are represented by the first digit, Freeform® screen height by the

second digit, Platform panel height by the third digit and Freeform® screen height by the last digit.

64" high panel - 6  
51" high panel - 5  
44" high panel - 4  
37" high panel - 3

To specify the correct panel junction, start with the highest Platform panel and move clockwise. For example: To specify a 3-way connection comprised of 64" high and 51" high panels, start with the highest panel, 64" - 6. Proceed clockwise, 5 for 51", 6 for 64" and 0 for no panel. The code is 6560

**Freeform® to Freeform® connector kits** also allow for a variety of configuration options including inline, two-way (L), three-way (T), and four way (X) connections.

Each condition, excluding the inline, includes a 1 1/2" square extruded aluminum connector post and the required number of Freeform® to Freeform® post connector clips. The inline condition only requires inline connector clips which mount directly into the frames of the adjoining screens to complete the connection. The connector post may be finished in any of the standard Platform paint finishes. Post connector clips are a standard black finish.

Universal Freeform connector kits include all required connector hardware and trim necessary to make 'L', 'T' and 'X' connections. Specify one height specific universal connector kit to accommodate any of the three corner conditions. Inline connector kits come complete with the required amount of connector clips.

### Product Code Key Example for Freeform® to Freeform® FSUC37

**FS** - Freeform Screen  
**U** - Universal Connection  
**C** - Connector Kit  
**37** - 37" High

**Inline connectors** connect two Freeform® screens in a straight connection.

**Universal connector kits** connect screens in any configuration.

**Universal Wall connector** kits anchors screen of any height to the wall at 90° angle at the start of a run.

### Finishes

Connector posts and Trim are available in any of the colors shown in our Color Guide. **Note:** Connector clips and brackets are standard in black.

Universal Wall connector is available in black only.

# FREEFORM® TO FREEFORM® CONNECTOR KIT OVERVIEW

---

## Freeform® to Freeform® Connections

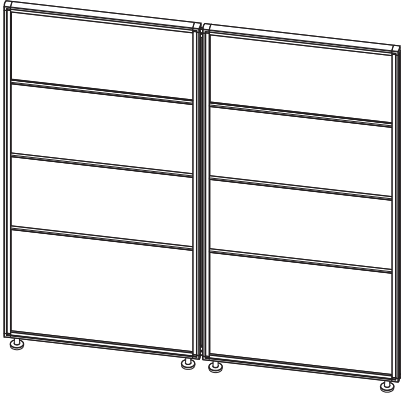

Inline Condition

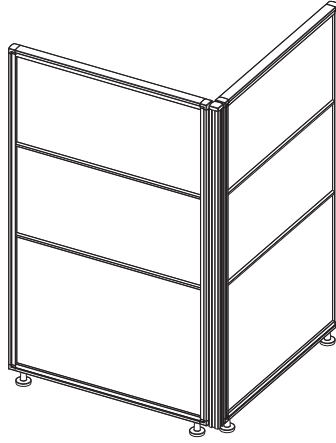

'L' Condition

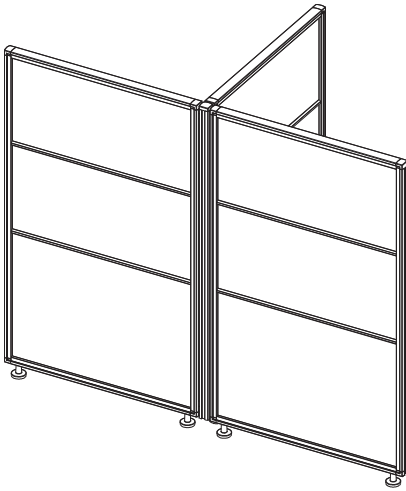

'T' Condition

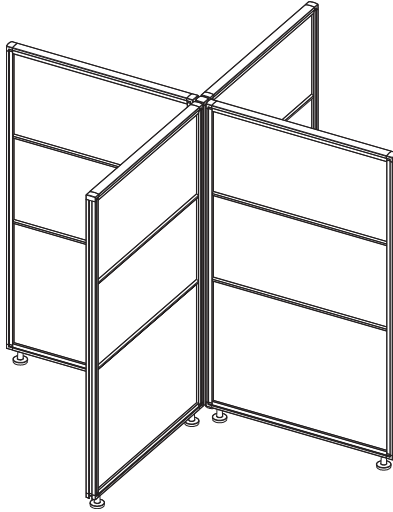

'X' Condition

# FREEFORM® TO FREEFORM® CONNECTOR KIT OVERVIEW

## Inline Condition

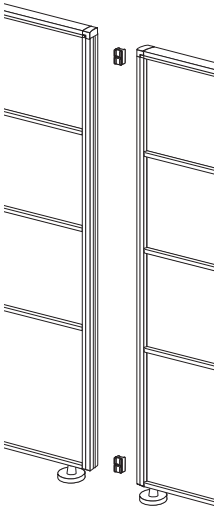

Inline connector kits attach Freeform® screens to each other to create a straight connection. Inline connector clips create a  $\frac{3}{8}$ " distance between the adjoining screens.

Inline connector kits come complete with top and bottom inline connector clips.

## 'L' Condition

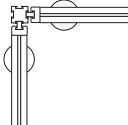
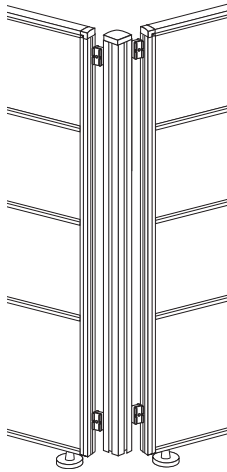

Universal connector kits attach 2 Freeform® screens to each other to create a 90° angle.

Universal Connection Kits come complete with top and bottom corner connection clips and connector post.

## 'T' Condition

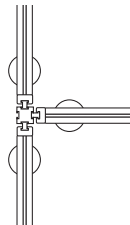
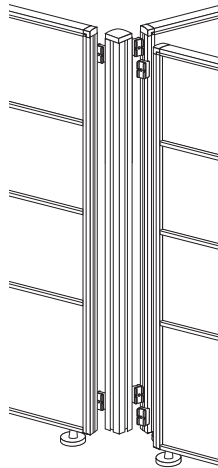

Universal connector kits attach Freeform® screens to each other to create two 90° angles.

Universal Connection Kits come complete with top and bottom corner connection clips and connector post.

## 'X' Condition

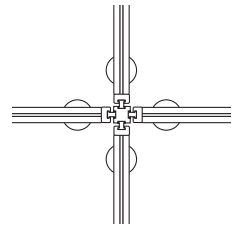
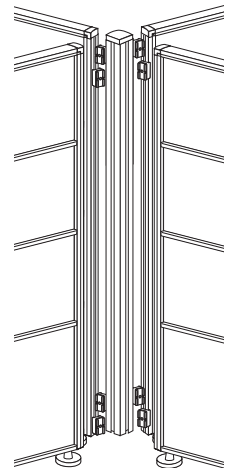

Universal connector kits attach Freeform® screens to each other to create four 90° angles.

Universal Connection Kits come complete with top and bottom corner connection clips and connector post.

# FREEFORM® TO PLATFORM CONNECTOR KIT OVERVIEW

---

## Freeform® to Platform Connections

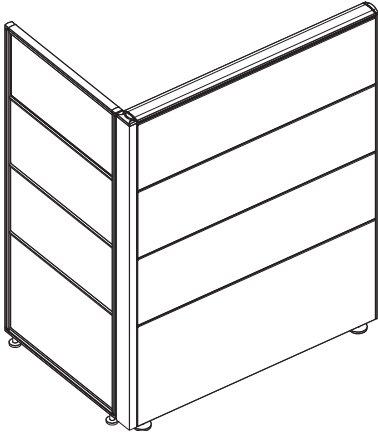

'L' Condition

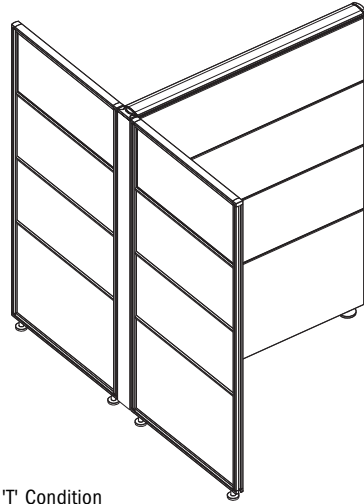

'T' Condition

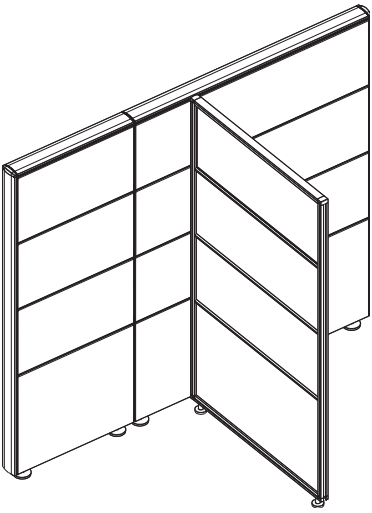

Off Module Condition

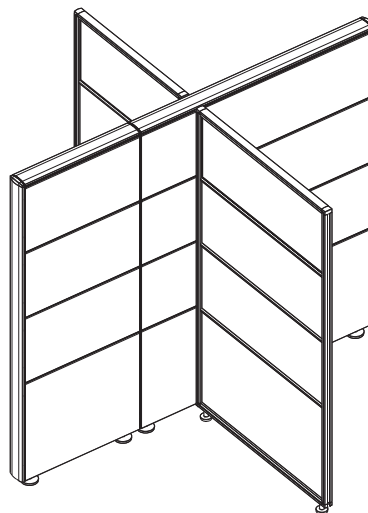

Off Module Back-to-Back Condition

# FREEFORM® TO PLATFORM CONNECTOR KIT OVERVIEW

## 'L' Condition

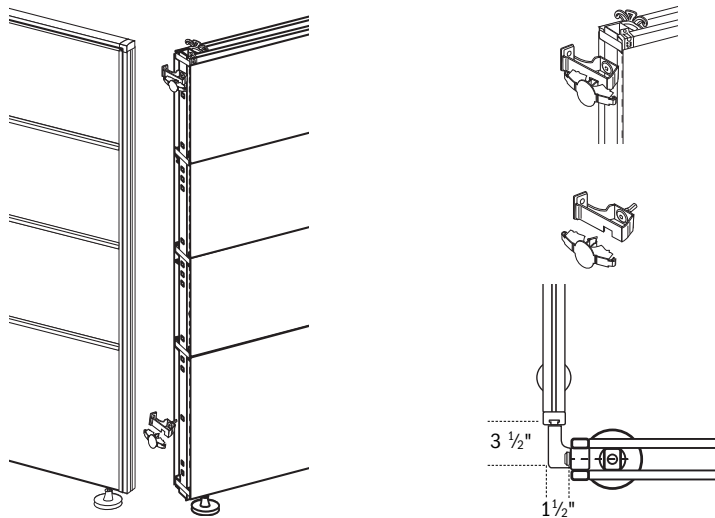

'L' Connectors attach Freeform® screens to a Platform frame at a 90° angle. 'L' connector kits come complete with 'L' condition end trim and Freeform® to Platform connector brackets

## 'T' Condition

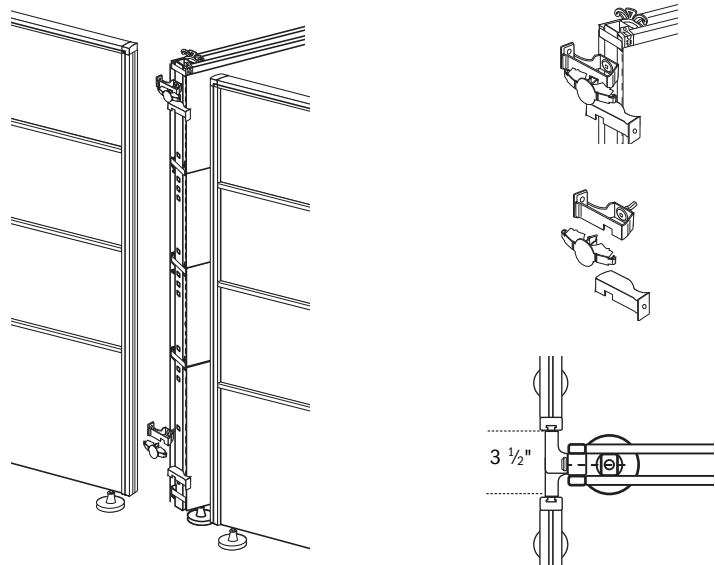

'T' Connectors attach 2 Freeform® screens to a Platform frame at a 90° angle. 'T' connector kits come complete with 'T' condition end trim and Freeform® to Platform connector brackets

# FREEFORM® TO PLATFORM CONNECTOR KIT OVERVIEW

## Off-module Condition

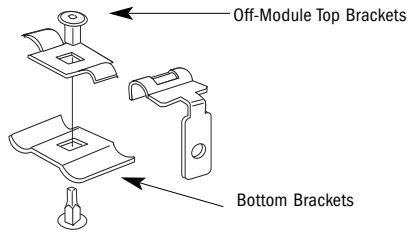
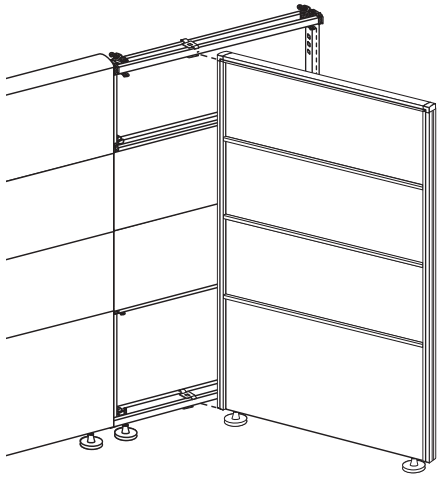

"Off-Module" brackets attach one Freeform® screen to a Platform frame off-module. The two connecting panels may be of unequal heights, however, the off-module screen cannot be higher than the adjacent Platform panel. To remove tiles on the Platform supporting panel, the off-module connection must be removed. Off-module connector kits come complete with top and bottom connector brackets.

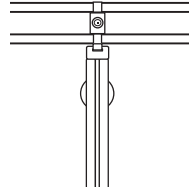

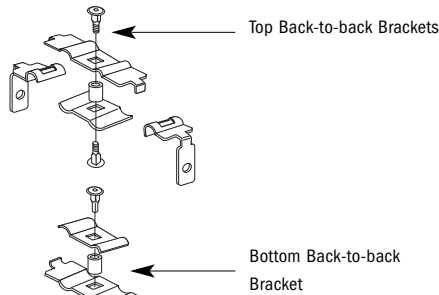
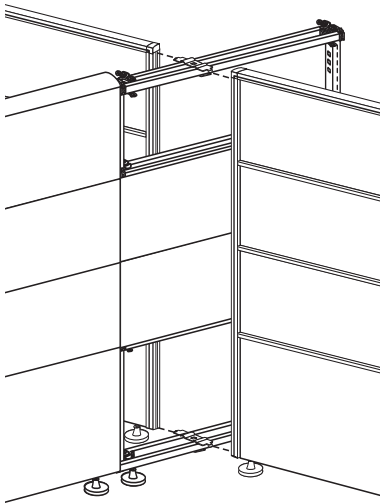

## Off-module Condition Back-to-back

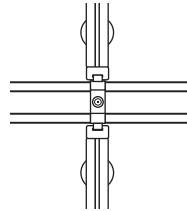

"Back-to-Back Off-Module" brackets attach two Freeform® screens to a Platform frame off-module. The connecting screens may be of unequal heights, however, the off-module screens cannot be higher than the adjacent panel. To remove tiles on the Platform supporting panel, the off-module connection must be removed. Back-to-Back off-module connector kits come complete with top and bottom connector brackets.

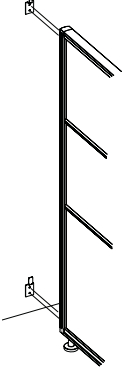

# Freeform to Freeform Connectors

Description	Product No.	H"	W"	Weight lbs.	List Price
<b>Inline Connectors</b>					
	FSSC	37/44/51		2	\$20
	FSSC64	64		2	\$29
<b>Universal Connectors</b>					
	FSUC37	37		2	\$91
	FSUC44	44		2	\$98
	FSUC51	51		2	\$104
	FSUC64	64		2	\$141
<b>Wall Connectors</b>					
	CFW			.1	\$35

# Freeform to Platform Connectors

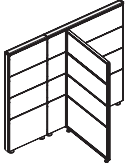
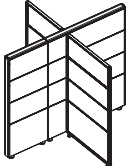
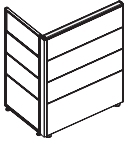
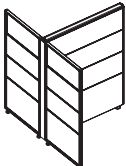
Description	Product No.	H"	W"	Weight lbs.	List Price
<b>Off-Module (1 Side)</b>					
	FSPOMC			2	\$65
<b>Off-Module (2 Sides)</b>					
	FSPOMBC			2	\$60
<b>L-Connectors (Freeform on LH side)</b>					
	FSPLC37LH	37		2	\$62
	FSPLC44LH	44		2	\$68
	FSPLC51LH	51		2	\$72
	FSPLC64LH	64		2	\$90
<b>L-Connectors (Freeform on RH side)</b>					
	FSPLC37RH	37		2	\$62
	FSPLC44RH	44		2	\$68
	FSPLC51RH	51		2	\$72
	FSPLC64RH	64		2	\$90
<b>T-Connectors (2 Freeform / 1 Platform)</b>					
	FSPTC37	37		2	\$71
	FSPTC44	44		2	\$75
	FSPTC51	51		2	\$80
	FSPTC64	64		2	\$103



# Platform to Freeform Connectors

Description	Product No.	H"	W"	Weight lbs.	List Price
-------------	-------------	----	----	-------------	------------

## T-Connectors (2 Platform / 1 Freeform)

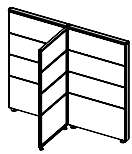

FPSTC37	37		2	\$123
FPSTC44	44		2	\$137
FPSTC51	51		2	\$151
FPSTC64	64		2	\$166

## X-Connectors (2 Platform / 2 Freeform)

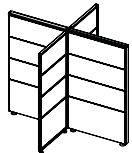

FPSXC37	37		2	\$114
FPSXC44	44		2	\$125
FPSXC51	51		2	\$133
FPSXC64	64		2	\$141

Description	Product No.	H"	W"	Weight lbs.	List Price
-------------	-------------	----	----	-------------	------------

## T-Connectors (2 Platform / 1 Freeform)

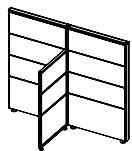

FPSTC6560			2	\$177
FPSTC6460			2	\$181
FPSTC6360			2	\$185
FPSTC5450			2	\$139
FPSTC5350			2	\$144
FPSTC4340			2	\$133

## X-Connectors (2 Platform / 2 Freeform)

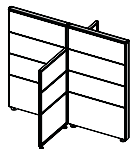





FPSXC6665			2	\$164
FPSXC6664			2	\$168
FPSXC6663			2	\$172
FPSXC6565			2	\$175
FPSXC6564			2	\$180
FPSXC6563			2	\$183
FPSXC6464			2	\$183
FPSXC6463			2	\$188
FPSXC6363			2	\$191
FPSXC5554			2	\$134
FPSXC5553			2	\$138
FPSXC5454			2	\$146
FPSXC5453			2	\$150
FPSXC5353			2	\$150
FPSXC4443			2	\$134
FPSXC4343			2	\$142





**C**  
**Tables, Supports &**  
**Electrical Accessories**



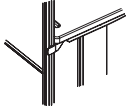
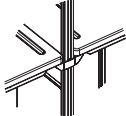

# Tables

Description	Product No.	D"	W"	Weight lbs.	1" Slimline	
					Nuform Solid	Nuform Woodgrain
<b>24" Deep</b>						
	FFT2436L	24	36	42	\$ 522	\$ 548
	FFT2442L	24	42	47	\$ 563	\$ 593
	FFT2448L	24	48	51	\$ 607	\$ 642
	FFT2454L	24	54	56	\$ 648	\$ 690
	FFT2460L	24	60	60	\$ 690	\$ 734
<b>30" Deep</b>						
	FFT3036L	30	36	49	\$ 585	\$ 618
	FFT3042L	30	42	51	\$ 638	\$ 676
	FFT3048L	30	48	60	\$ 690	\$ 734
	FFT3054L	30	54	66	\$ 743	\$ 791
	FFT3060L	30	60	71	\$ 797	\$ 850
Description	Product No.	D"	W"	Weight lbs.	1" Slimline	
					Nuform Solid	Nuform Woodgrain
<b>24" Deep</b>						
	FFT2436TL	24	36	42	\$ 534	\$ 569
	FFT2442TL	24	42	47	\$ 579	\$ 619
	FFT2448TL	24	48	51	\$ 623	\$ 669
	FFT2454TL	24	54	56	\$ 668	\$ 719
	FFT2460TL	24	60	60	\$ 712	\$ 768
<b>30" Deep</b>						
	FFT3036TL	30	36	49	\$ 601	\$ 644
	FFT3042TL	30	42	51	\$ 657	\$ 706
	FFT3048TL	30	48	60	\$ 712	\$ 768
	FFT3054TL	30	54	66	\$ 768	\$ 831
	FFT3060TL	30	60	71	\$ 824	\$ 894

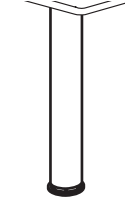
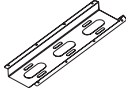
# Table Supports & Accessories

Description	Product No.	D"	W"	Weight lbs.	List Price
<b>Freeform Single Docking Bracket</b> 	FWSDB			2	\$21
<b>Freeform Back-to-Back Docking Bracket</b> 	FWSBDB			2	\$34
<b>Freeform Front Edge Support Bracket</b> 	FWSFESB			2	\$23
<b>Mid-Span Support Bracket</b> 	FF-MSSB			1	\$16
<b>Post Leg</b> 	FFLEG28.5			4	\$66
<b>Cable Management Tray</b> 	CMT18 CMT30		18 30	2 3	\$26 \$34

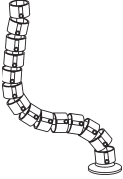
# Electrical Accessories

Description	Product No.	H"	W"	Weight lbs.	List Price
<hr/>					
<b>Freeform Wire Casing</b>					
	<b>FWC</b>			.1	<b>\$89</b>
<hr/>					
<b>Power Bar</b>					
	<b>PBAR</b>			2	<b>\$39</b>
<hr/>					









# Freeform® Surface Materials

## UPHOLSTERED SCREENS

Freeform® screen core may be specified in fabric, clear or white polycarbonate and Resin. Fabric wrapped core may be covered with our standard fabrics, or covered with COM. Use of any COM must be approved by Inscape prior to acceptance of order. Refer to "Conditions of Sale, Orders involving Customer's Own Material (COM)".

### Grade 1 Fabric

Universe		Tracery		Strata		Meander	
1000	Crème Brulee	1025	Egret	1050	Bronze	1061	Sandshell
1001	Grey Mist	1026	Straw	1051	Sandstone	1062	Overcast
1002	Wheat	1027	Brindle	1052	Coal	1063	Agate Taupe
1003	Seneca	1028	Sea Spray	1053	Chalk	1064	Nightshadow
1004	Milky Way			1056	Jet		
1005	Mica			1060	Peridot		
1006	Cosmic						
1007	Depth						
<b>Twigs</b>		<b>Quasar</b>		<b>Pronto Solid</b>		<b>Asana</b>	
1161	Sycamore	1182	Corona	1200	Drift	1471	Harmony
1163	Juniper	1186	Pulsar	1201	Windblown	1474	Sirsha
1164	Sassafras	1187	Sunbeam	1202	Erosion	1475	Bhakti
1166	Hawthorn	1188	Lunar	1210	Clear Sky	1477	Raja
1167	Linden	1189	Orion	1215	Raven	1478	Bliss
1168	Buckeye	1190	Starfire	1220	Darkness	1479	Lucid
1170	Poplar	1192	Eclipse	1280	Breeze	1480	Chakra
1171	Hickory			1285	New	1481	Karma
<b>Anchorage</b>		<b>Resonance</b>		<b>Fine Point</b>			
1400	Green Apple	1416	Quarry Blue	1111	Echo	1336	Fresco
1401	RedDelicious	1417	Midnight	1112	Chant	1337	Balique
1402	Onyx	1419	Sunshine	1113	Tone	1338	Vintage
1403	Slate	1421	Asteroid	1114	Carillion	1339	Silvern
1404	Amber	1425	Coffee Bean	1115	Chime	1340	Sterling
1405	Willow	1426	Geranium	1116	Lyric	1341	Porcelain
1406	Flax	1427	Thistle				
1407	Angora	1431	Chocolate				
1412	Green Olive	1432	Lapis				
1413	Goose	1434	Vanilla				
1414	Cumin	1435	Pumpkin				
1415	Deep Water	1436	Wolf				

### Grade 2 Fabric

*Kyoto		Curtain Call		Backdrop		Pattern Dots	
2362	Fuji	2100	Latte	2120	Mocha	2090	Ivory Pearl
2363	Natsu	2101	Desert	2121	Capri	2091	Asparagus
2364	Sake	2102	Dove	2122	Mineral	2092	Silver Gray
2366	Shiro	2103	Pebble	2123	Barley	2093	Willow
2369	Sumo	2104	Tawny	2124	Bonsai	2094	Sierra
2370	Kimono	2105	Sea	2125	Cement	2095	Dark Champagne
2372	Bamboo			2126	Charcoal		
<b>Crescents</b>							
2140	Haystack						
2141	Charcoal Dust						
2142	Sandy Shore						
2143	Wheat Grass						
2144	Stone						
2145	Iceberg						

\*Terratex® is a registered trademark of Interface Fabric Group and designates fabrics that are made from 100% recycled or compostable material using increasingly sustainable manufacturing practices to produce a high quality product that is recyclable at the end of its useful life.

# Freeform® Surface Materials

---

## UPHOLSTERED SCREENS

### Grade 3 Fabric

#### \*Drift

3080	Bloom
3082	Graphite
3084	Mocha
3086	Stone
3087	Mink
3088	Squall

### Grade 5 Fabric

#### Sprite

5000	Linen
5001	Powder
5002	Khaki
5003	Kiwi
5004	Harvest
5005	Snow

### Grade 7 Fabric

#### Ditto

7000	Beach Glass	7010	Comet
7001	Sandy Beach	7011	Celestial
7002	Breezy Blue	7012	Space
7003	Storm Cloud	7013	Gravity
7004	Shoreline	7014	Motion
7005	Wave		

#### Note:

\* Please see an Inscape Fabric Card for a listing and sampling of all color ways

\*Terratex® is a registered trademark of Interface Fabric Group and designates fabrics that are made from 100% recycled or compostable material using increasingly sustainable manufacturing practices to produce a high quality product that is recyclable at the end of its useful life.

# Freeform® Surface Materials

	Color Code	Name	Textured Colors
<b>Finish Code Matrix</b> Screen frames are available in any of the colors shown in our color guide.	004	Bisque	
	010	Chinook	
	013	Onyx	♣
	022	Frost	
	023	Arctic	
	024	Champagne	
	052	Titanium	
	055	Mushroom	
	063	Krypton Reflections	♣
	066	Cinder Reflections	♣
	112	Soapstone	
	121	Warm White	
	122	Mist	
	123	Sandstone	
	124	Light Taupe	
	126	Medium Gray	
	127	Nickel Reflections	♣
	128	Slate Reflections	♣
	160	Quartz	
	168	Glacier White	
	205	Charcoal Gray	
	217	Pebble Gray	
	223	Deep White	
	255	Mocha	
	274	Latte	
	281	Juniper Reflections	
	282	Quicksilver Reflections	
	284	Sunstone Reflections	
	290	Aluminum Leaf	
	300	Sasha	
	301	Elson	
	302	Shade	
	303	Anonymous	
304	Urban		
305	Dorian		
306	Dover		
307	Jubilee		
308	Softer Tan		
309	Storm Cloud		
310	Rice Grain		
311	Ramie		
312	Favorite Tan		
314	High Tea		
315	Stone Reflections		
316	Dovetail Reflections		
317	Yorkshire		
318	Coriander		
319	Snowcap		
320	Salem		
321	Burnt Sierra		
322	Drizzle		
323	Scroll		
324	Cumin		
325	Seagull		
326	Smoke		
327	Gunpowder Blue		
328	Moonlight		
329	Starlight Silver		
330	Martini Reflections		
332	Laminate White		

♣ - indicates availability as textured color.

# Freeform® Surface Materials

---

## RESIN FINISHES

### Grade 1

A202 Caramel  
A204 Eiderdown

### Grade 2

A205 Quattro Platinum  
A206 Bear Grass Light  
A207 Drift Green

### Grade 3

A208 Fossil Leaf

## TABLE FINISHES

Freeform® tables are available in Nuform Solid colors and Nuform Woodgrain

### Nuform Solid

F121 Warm White  
F122 Mist  
F123 Sandstone  
F127 Frosty White

### Nuform Patterns\*

F21 Fibers Concrete  
F22 Studio White Dust  
F23 Cashmere Fiber  
F24 Olympia Apple  
F26 Urban Walnut

### Nuform Woodgrain

F06 Walnut  
F08 Tannery Maple  
F09 Honey Brown  
F10 Musique Maple  
F11 Jewel Cherry  
F14 Laguna Pebble  
F15 Camby Cherry  
F16 River Cherry  
F18 Milky Sketch

\***Nuform patterns** have been pre-tested and approved but are not part of Inscape's standard offering. These Nuform foils are subject based on availability from the vendor.







# CARE & MAINTENANCE

---

## General Information

The following information provides general guidelines for cleaning and maintaining Freeform® products.

### Freeform® Fabric Screen Segments

- Vacuum or lightly brush screen fabrics to remove dirt build-up.
- Promptly remove stains by blotting, not rubbing the fabric to retain pile texture.
- Fabric may be cleaned with mild water-free solvents or water-based cleaning agents or foam. Always follow the manufacturer's instructions and test clean a non-visible area first.

### Freeform® Glazed Screen Segments

- Glazed segments are available in acrylic glass.
- Clean acrylic with a clean soft cloth and warm soapy water.

### Freeform® Screen Frame Trim

- Clean painted frame trim with a soft damp cloth.
- Touch up paint is available to repair minor scratches on painted trim finishes.

### Freeform® Whiteboard Screens

- Use only dry erase markers with whiteboards.
- Clean whiteboards with eraser and cleaner formulated for whiteboards.
- INSCAPE recommends using Sanford Expo Dry Erase Markers and Sanford Whiteboard Cleaner.

### Polycarbonate Screens

- Clean with a clean, dry, absorbent, lint-free, non-abrasive cloth.
- DO NOT USE rayon or polyester cloths which can scratch the plastic.





# INSCAPE

67 Toll Rd.  
Holland Landing, ON  
Canada  
L9N 1H2

T 905.836.7676  
F 905.836.6000

[inscapesolutions.com](http://inscapesolutions.com)